

LONKING 龙工

Efficiency Rules the Future

LG160DTIII

Internal Combustion Forklift

Cabin with Broad View
Excellent Stability and Security
Advanced Ergonomical Design
Powerful Turbocharged engine



	LG160DT(Y/W)	LG160DT(SZ/SA)
■ Rated Power (kW):	129/2200	142/2200
■ Rated Capacity (kg):	16000	16000
■ Power Type:	DIESEL	DIESEL

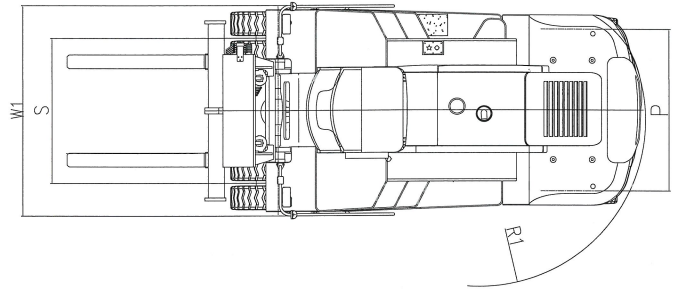
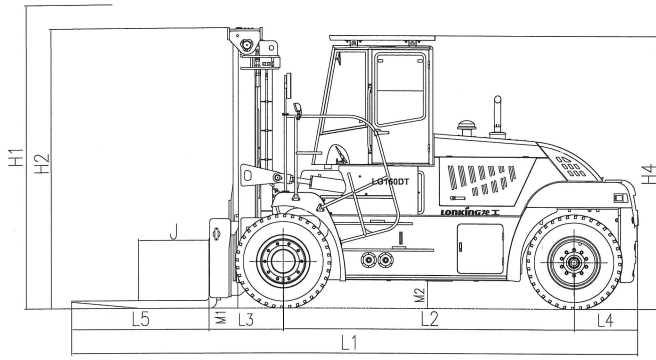

MODEL	LG160DT(Y/W)	LG160DT (SZ/SA)	
Power type	Diesel	Diesel	
Rated capacity(kg)	16000	16000	
J Load center(mm)	600	1200	
H1 STD Max lifting height(mm)	3500	4000	
L5*W*T STD Fork size(mm)	1800×220×100	2400×250×100	
Mast tilt angle(deg)	6/12	5/10	
L3 Front overhang(mm)	968	925	
L4 Rear overhang(mm)	840	795	
Overall dimension			
L 1 Overall length(with fork)(mm)	7410	7870	
W1 Overall width(mm)	2752	2560	
H2 STD Mast lowered height(mm)	3675	3685	
H4 Overhead guard height (mm)	3566	3262	
R1 Min.turning radius (mm)	5300	5175	
Min.intersecting aisle(mm)	8288	8700	
Performance Date			
Max.traveling speed(km/h)load/unload	25/28	28/30	
Max.lifting speed(mm/s)load/unload	280/300	320/360	
Max.gradient(%)	20	28	
Self weight(kg)	23500	24000	
S/P Tread(front/rear)(mm)	1895/2120	1878/2020	
L2 Axle distance(mm)	3800	3750	
Min.ground clearance	M2 Mast(mm)	330	250
	M1 Frame(mm)	350	310
STD Engine	Yuchai YC6J175-T302 WEICHAI WP6G190E330	CumminsQCB6.7	
Rated power(kw)	129	142	

Optimal Engine(for 16t)

Engine Model	Manufacturer	Rated Power (kw/rpm)	Max.Torque (Nm/rpm)	Bore/Number of Cylinders/Displacement (mm/L)	Fuel Consumption (g/KW·h)
YC6J175-T302	Yuchai	129/2200	710/1400-1700	105/6/6.494	230
WP6G190E330	Weichai	142/2200	760/1400-1600	105/6/6.7	225
QSB6.7-190	Cummins	142/2200	931/1500	107/6/6.7	230

LONGKING (FU JIAN) INTERNATIONAL TRADE CO.,LTD.

LONGKING HOLDINGS LIMITED

Add:26 Minyi Road,Xinqiao,Songjiang Industrial Zone,Shanghai
P.C: 201612

Tel: +86-21-3760 2242

http://www.lonkinggroup.com

E-mail:export@lonking.cn

Lonking, Lonking CDM Series and their respective logos, as well as corporate identity in this leaflet are trademarks of Lonking Holdings Ltd., and may not be used without written permission.

2019/04

**For more information on Lonking products,
please visit www.lonkinggroup.com**



**Specifications and design are subject to change without prior notice.
Machines shown may not include optional accessories.**